

Astra Walker's capacitive tap sensor is one of our latest and most highly anticipated collection releases. It responds to the global demand of contactless hand hygiene, prioritising health and safety above all else

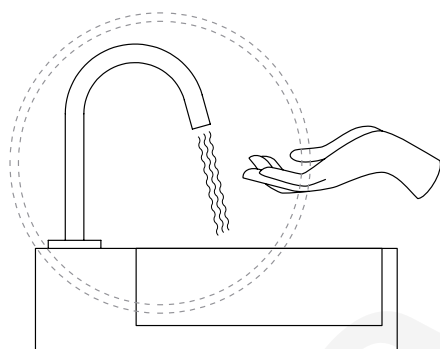

When hands come into close proximity to the tap, an increase in capacitance is detected and water flows automatically.

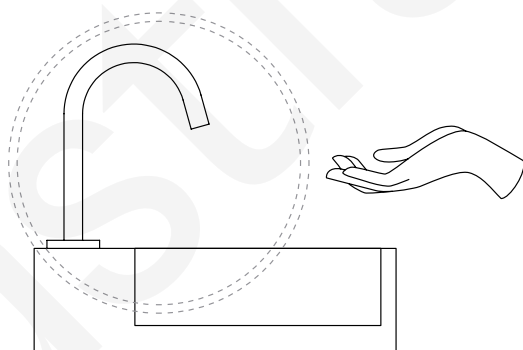

When the hands are removed a decrease is detected, turning off the water and returning the tap to standby mode.

New Age Technology

Cutting edge capacitive sensor technology, compared to infrared sensor

Energy Saving

Low power usage, economical and reliable. Battery life time - 3 years at 150 times/day.

Water Saving

Efficient water saving technology, achieving a 6 Star WELS rating

Seamless Experience

Precise sensor accuracy for a seamless user experience

Accuracy

5 levels of sensitivity for waterflow accuracy and efficiency

Safety

Extra fail-safe protection 'time out' feature

Minimal Maintenance

Self-calibration to reduce system maintenance and enhance stability

For more Sensor product information visit astrawalker.com.au

BENCH SPOUT WITH CAPACITIVE SENSOR TECHNOLOGY

INSTALLATION TO SUIT:

A80.00**A80.07**

The capacitive sensor tap works by detecting any increase in capacitance within a close proximity. Capacitance is a physical property of the human body (or conductive element) which enables it to store electrical energy and act as a natural capacitor.

When the user comes into close proximity to the tap, an increase in capacitance is detected and water will flow. When the user leaves, a decrease is detected and the sensor will return to its normal standby mode.

The sensor tap is operated by a battery pack containing 6 AA lithium batteries for the power supply.

Ensure water lines are completely flushed prior to fitting to avoid damage to solenoid.

- Tapware to be installed by a licenced plumber in accordance with AS/NZS 3500:2021
- Recommended working water pressure 150 - 500kPa
- Maximum water temperature is 65 deg C
- After completing the installation check function of tapware and ensure no water leaks.

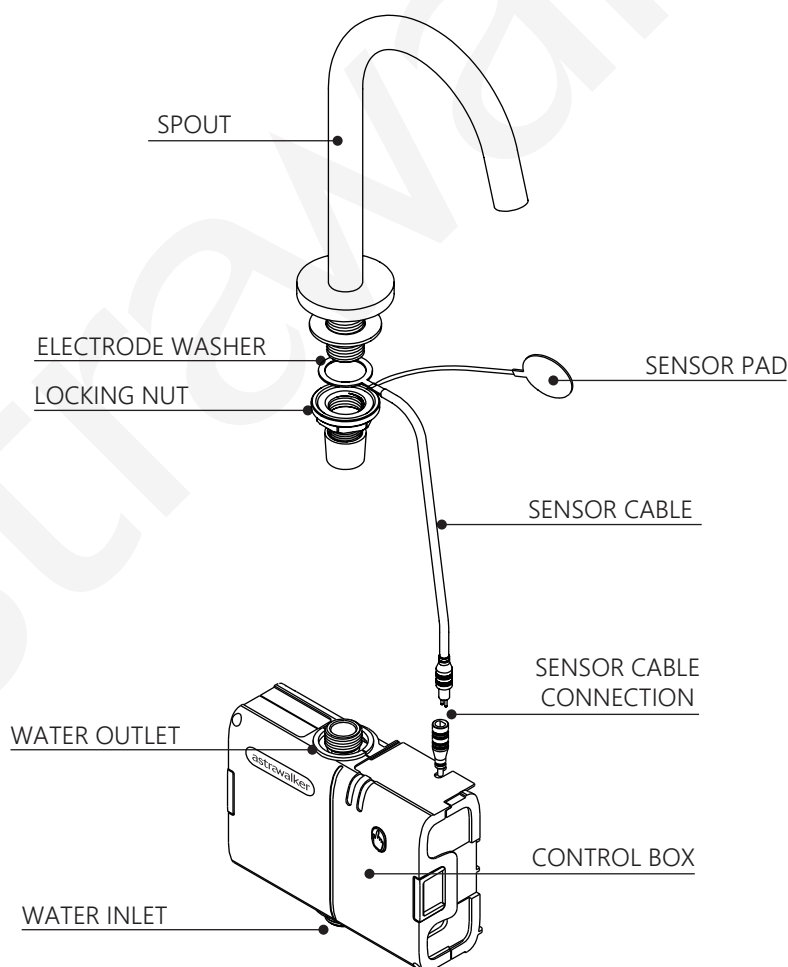

BENCH SPOUT WITH CAPACITIVE SENSOR TECHNOLOGY

- 1) Determine the position of the tap mounting hole in the sink or bench top. Hole size required is $\varnothing 25\text{mm}$ with a maximum bench top thickness of 30mm.
- 2) All mounting surfaces must be non-metallic and non-conductive. NOTE: The plumbing fittings including sensor box must not be within 250mm of conductive materials including steel framework and other copper plumbing.
- 3) It is critical all components which are fixed behind the wall are easily accessible at all times during installation and maintenance, and an access panel must be constructed.

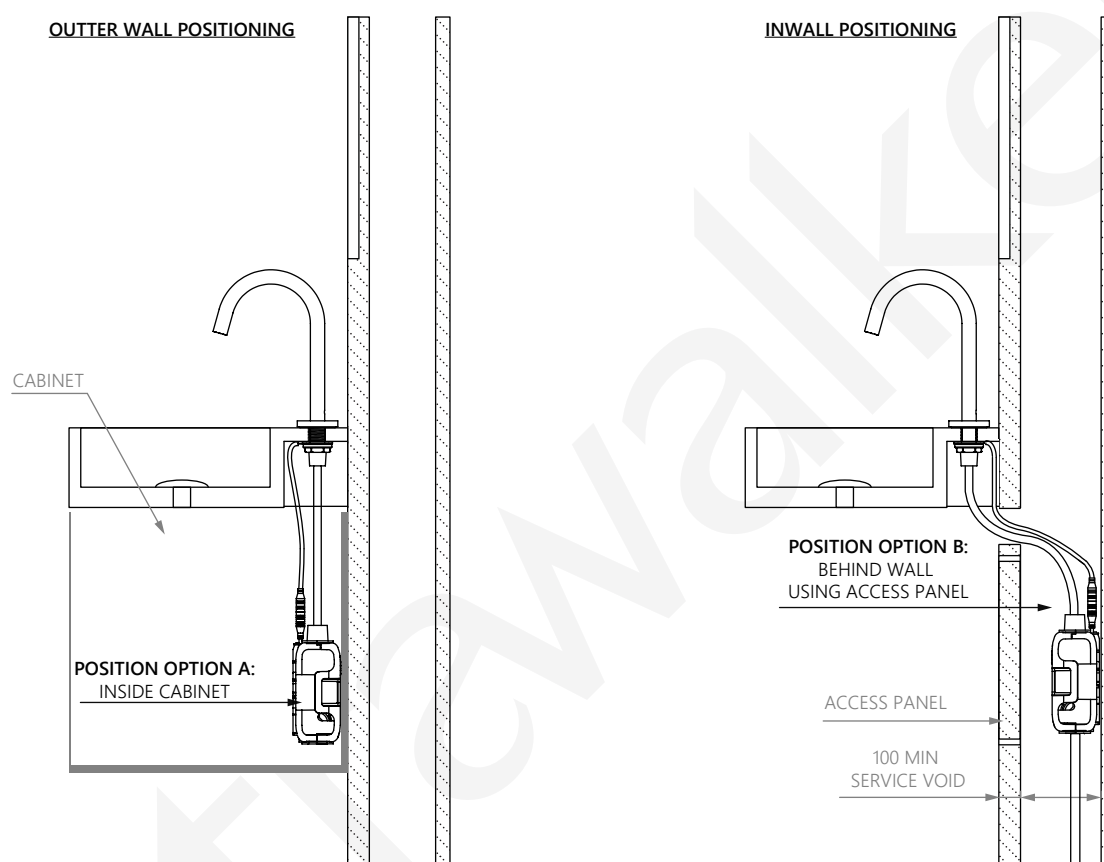

NOTE: The box must be within 1m of the electrode washer behind the spout.

- 4) Fit spout to sink - avoid using teflon tape for optimum sensitivity.
- 5) Tighten the electrode washer under the sink, between the lock nut and rubber spacer. Please ensure the electrode washer is not in contact with a metallic or conductive sink or surface. The electrode washer must be in contact with the brass thread on the spout to ensure optimum detection.
- 6) Remove the double-sided tape under the Sensor PAD, then stick it on the wall or cabinet, as far away from the outlet as possible.
- 7) Check the sensor cable is securely connected to the electrode washer.

BENCH SPOUT WITH CAPACITIVE SENSOR TECHNOLOGY

8) Prepare the box by unscrewing the screws to remove the cover then:

(i) push the green part

(ii) pull the white part

Remove the valve and the battery pack.

9) Determine and check the correct position of the box, ensuring that it's position allows you to make the hydraulic connections without creating unnecessary stress or kinks on the hoses or sensor cable. The box must be within 800mm of the electrode washer behind the spout.

10) Control box connections

(i) Attach flexi hose to water outlet.

(ii) Fit tap supply hose to water inlet of the tap.

(iii) Attach wiring loom to 4 pin electrical socket and tighten locking ring.

(vi) Attach G1/2" mains water supply to water inlet connection on control box.

11) Fix the box to the wall, and attach water hoses to the inlet and outlet valves.

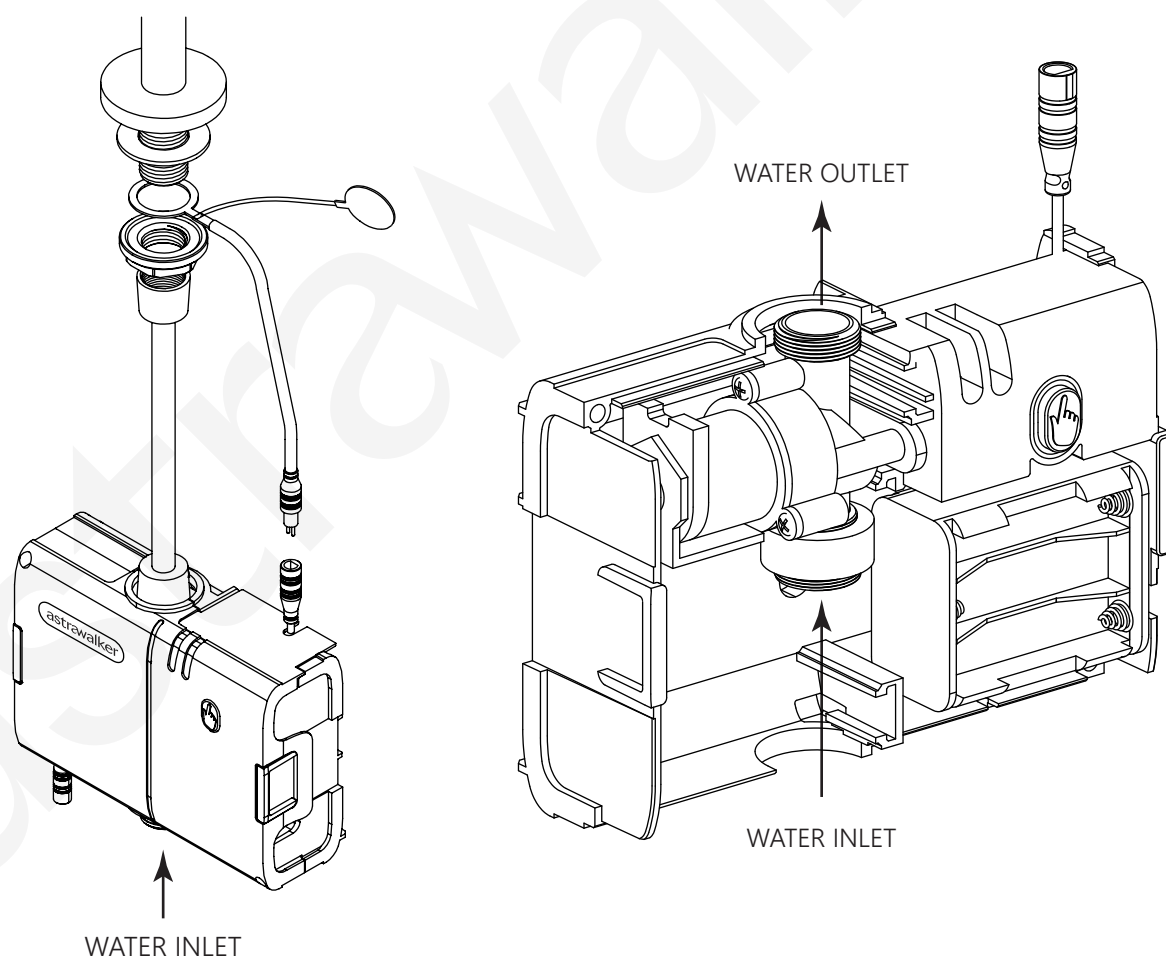

BENCH SPOUT WITH CAPACITIVE SENSOR TECHNOLOGY

12) Connect the sensor cable connector to the box. Ensuring that the sensor cable is not stretched or in contact with the water hoses.

13) Open water supply, which will allow water to flow into the valve (water may flow from tap - check for leaks)

14) Insert and connect batteries.

Place battery holder in the box and plug the battery holder to the corresponding connector in the box (connector with black and grey cable).

15) Calibration

(i) Immediately after connecting the power supply, stand at a distance of 1m away from the spout, making no contact with the spout, box or any components of the installation.

NOTE: It is imperative that no contact is made with the spout during this calibration phase (when the LED is lit) as this can impact the sensor's performance.

(ii) During calibration, the green LED flashes and the water flows from the spout for 10 seconds. If calibration is successful, the spout will close the running water. A small amount of water will dispense to indicate the calibration is successful.

(iii) If calibration is unsuccessful, the box's red LED lights up and the water flows for a second time. In this case, unplug and reconnect the box's batteries in order to reinitialise the calibration process. If the problem persists consult trouble shooting.

16) Check there are no water leaks near the hoses, spout and valve. Then close the box cover using the two screws.

BENCH SPOUT WITH CAPACITIVE SENSOR TECHNOLOGY

Adjusting sensitivity:

After the calibration phase, activate and deactivate the faucet 3 to 4 times. This should allow the sensor to automatically optimise sensitivity to its installation conditions, but if the sensor sensitivity is not satisfactory press the button to adjust it. Throughout the product's lifetime the sensor will auto-calibrate to ensure that the system maintains a stable performance.

The sensor has 5 levels of sensitivity:

Level 1: very low sensitivity (<3cm)

Level 2: low sensitivity (about 5cm)

Level 3: medium sensitivity (about 7cm) -Default setting

Level 4: high sensitivity (10cm)

Level 5: very high sensitivity (>10cm)

To adjust the sensitivity:

- (i) The level of sensitivity can be set by using the green button.
- (ii) To enter the settings mode you must press the green button for 10 seconds (until the green LED is permanently lit).
- (i) Release the button.
- (i) The sensitivity level is indicated by a series of flashes. For example, level 2 is indicated by 2 flashes.
- (i) Each time the button is pressed the sensitivity level will increase +1. At level 5, press once more and the system will go back to level 1.

After adjusting the level, press the button for 5 seconds to validate. The 2 green and red LEDs will flash once. After adjustment, the system will reboot and restart 1 cycle of auto-calibration (STEP 10)

Maintenance

When batteries reach a low level the box's red LED will blink 3 times per minute. This will continue for around 5 days before the box's batteries are empty.

Once the batteries are empty, the box's electronics will force the solenoid valve to close. The red LED will flash continuously until batteries are changed.

Further Assistance

Should any further assistance or troubleshooting be required please contact Astra Walker customer care on 02 8838 5100.

Warranty

All components of the Sensor Tap range are covered by a comprehensive 24 month warranty on all parts and labour.

*Refer to the website for further details on warranty and care.
<https://www.astrawalker.com.au/about/warranty>

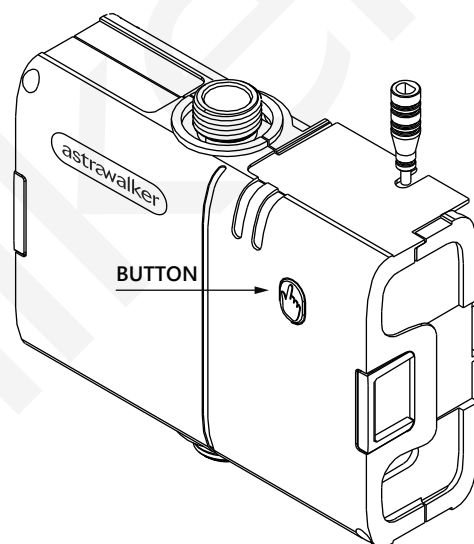

BENCH SPOUT WITH CAPACITIVE SENSOR TECHNOLOGY

Double Spout Installation

For the installation of two or more spouts, ensure the layout follows the below.

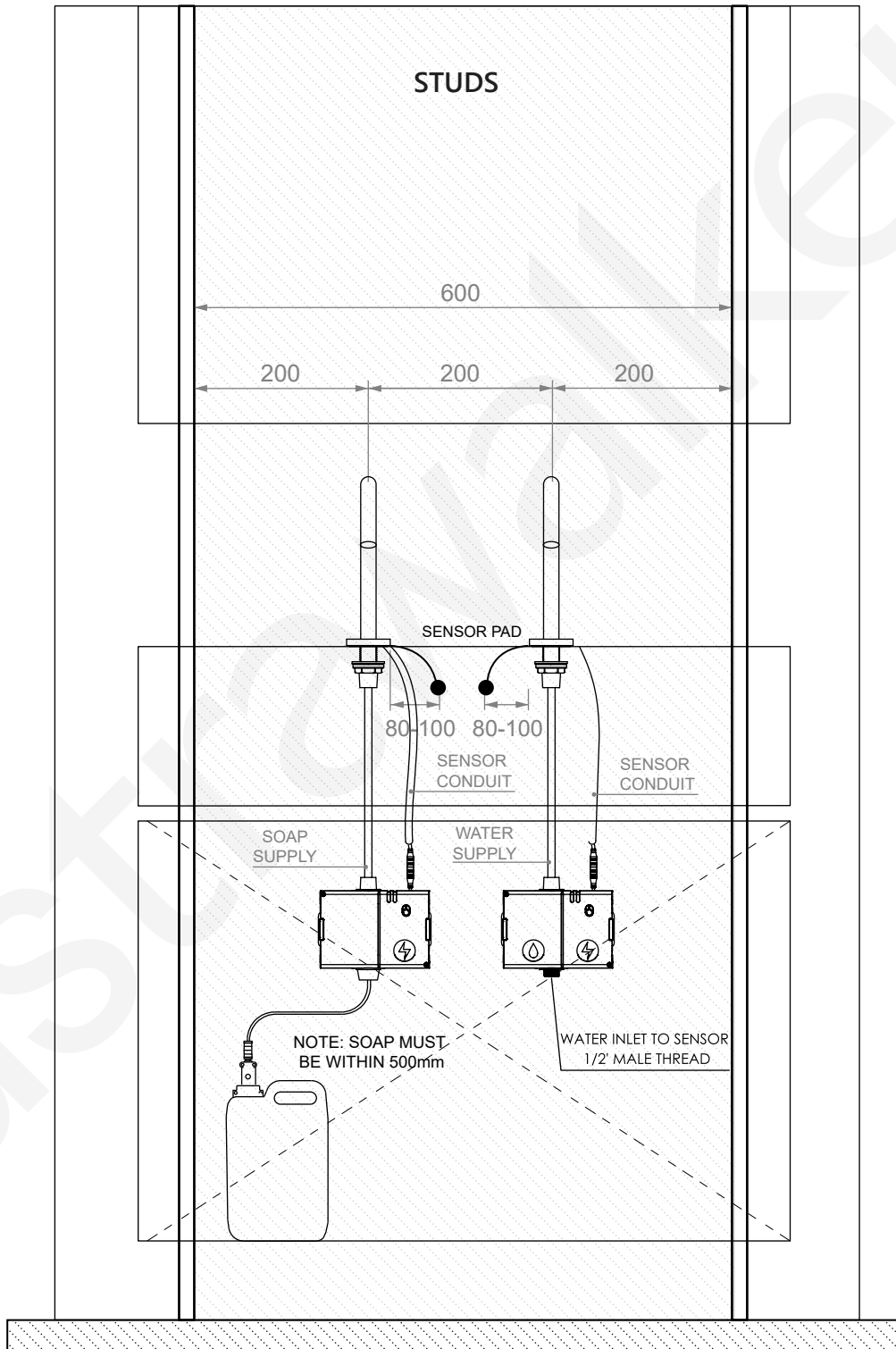

astrawalker

Head Office & Showroom
215 North Rocks Road
North Rocks NSW 2151
Phone (02) 8838 5100
Email northrocks@astrawalker.com.au

Instagram
[@astrawalkerofficial](https://www.instagram.com/astrawalkerofficial)
Website
astrawalker.com.au